

Trokomat

Entlüftungseinrichtung



Abbildung 1
Figure 1

**Explosions-
darstellung**
Exploded view

Luftführende Teile
sind blau gefärbt.
Air-bearing parts are
colored blue.

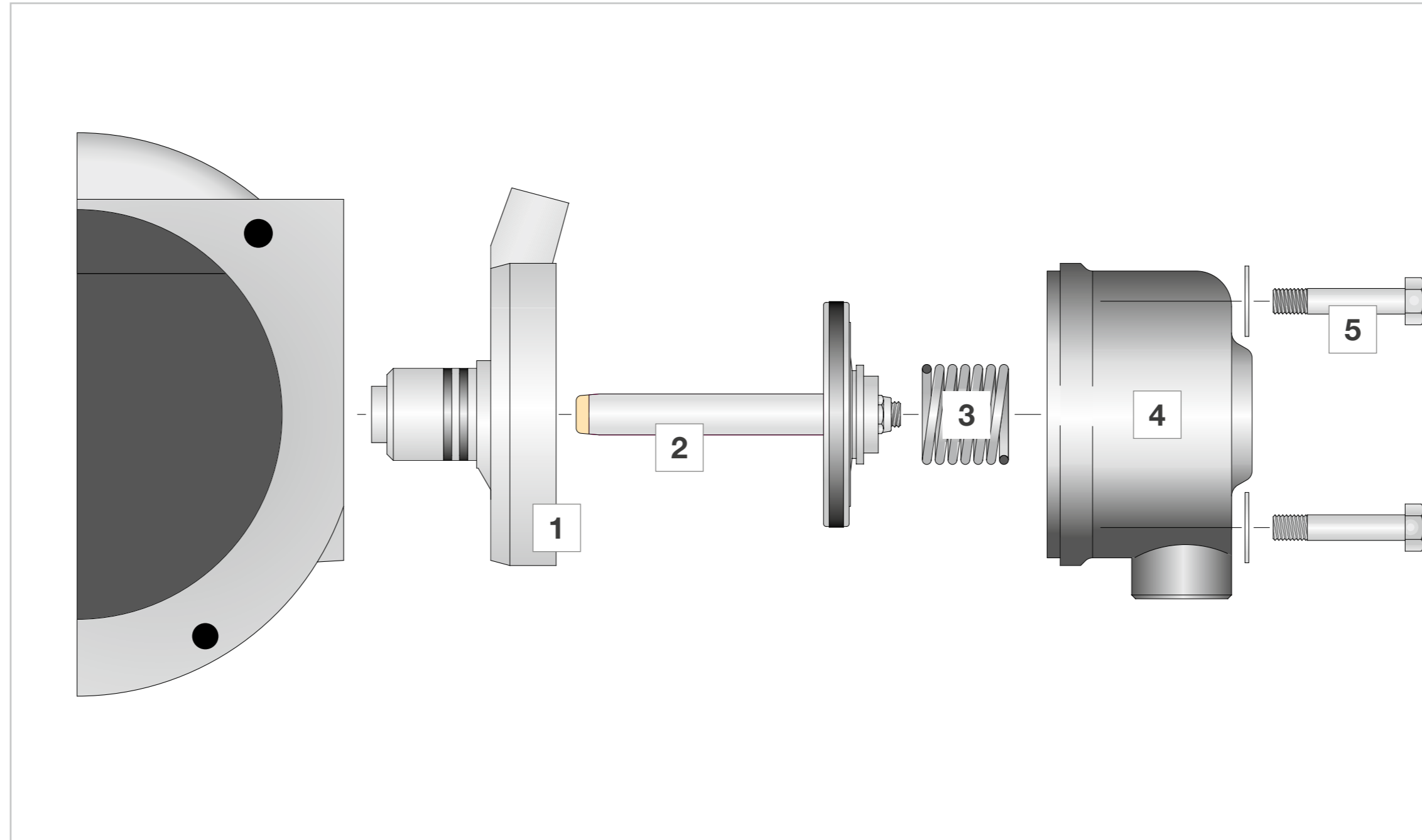
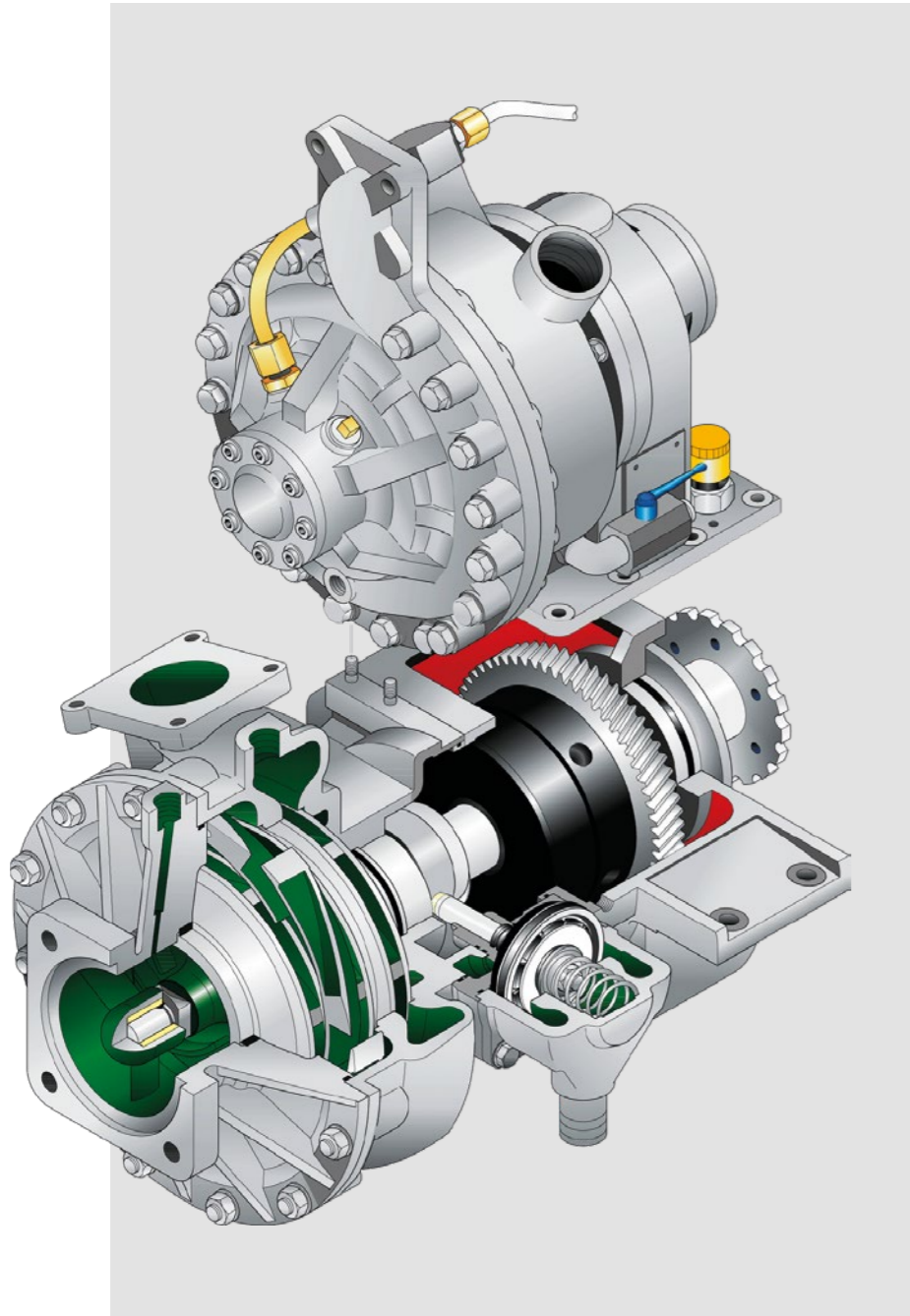

Abbildung 2
Figure 2

**Arbeits-
stellung**
Operating
position

Wasserführende Teile
sind grün gefärbt.
Water-bearing parts are
colored green.

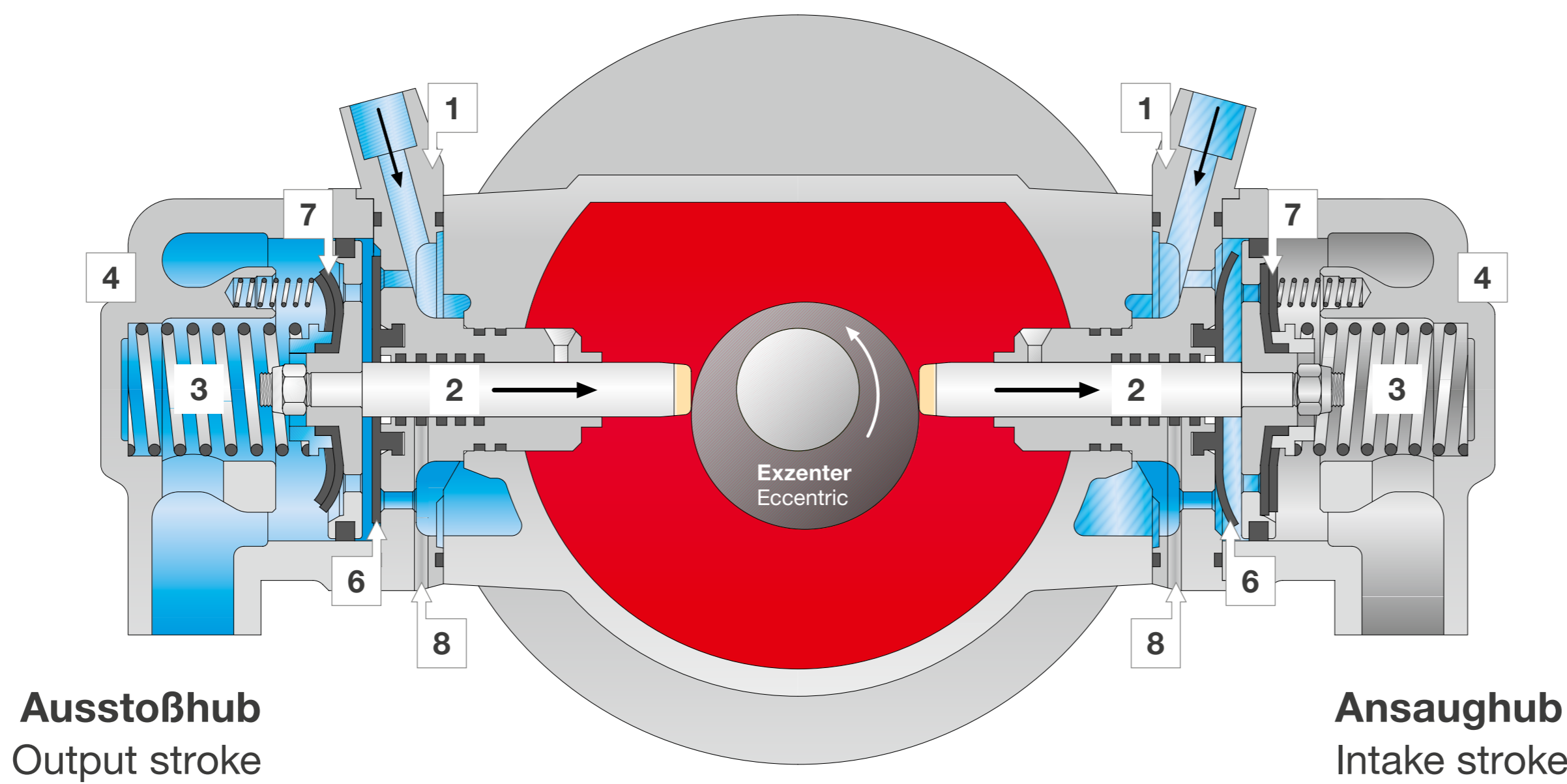

Abbildung 3
Figure 3

Ruhestellung
Rest position

- 1 Lagerflansch**
Bearing flange
- 2 Kolben komplett**
Piston complete
- 3 Druckfeder**
Pressure spring

- 4 Zylinderkappe**
Cylinder head
- 5 Sechskantschraube**
Hexagon screw
- 6 Einlassmembrane**
Inlet diaphragm

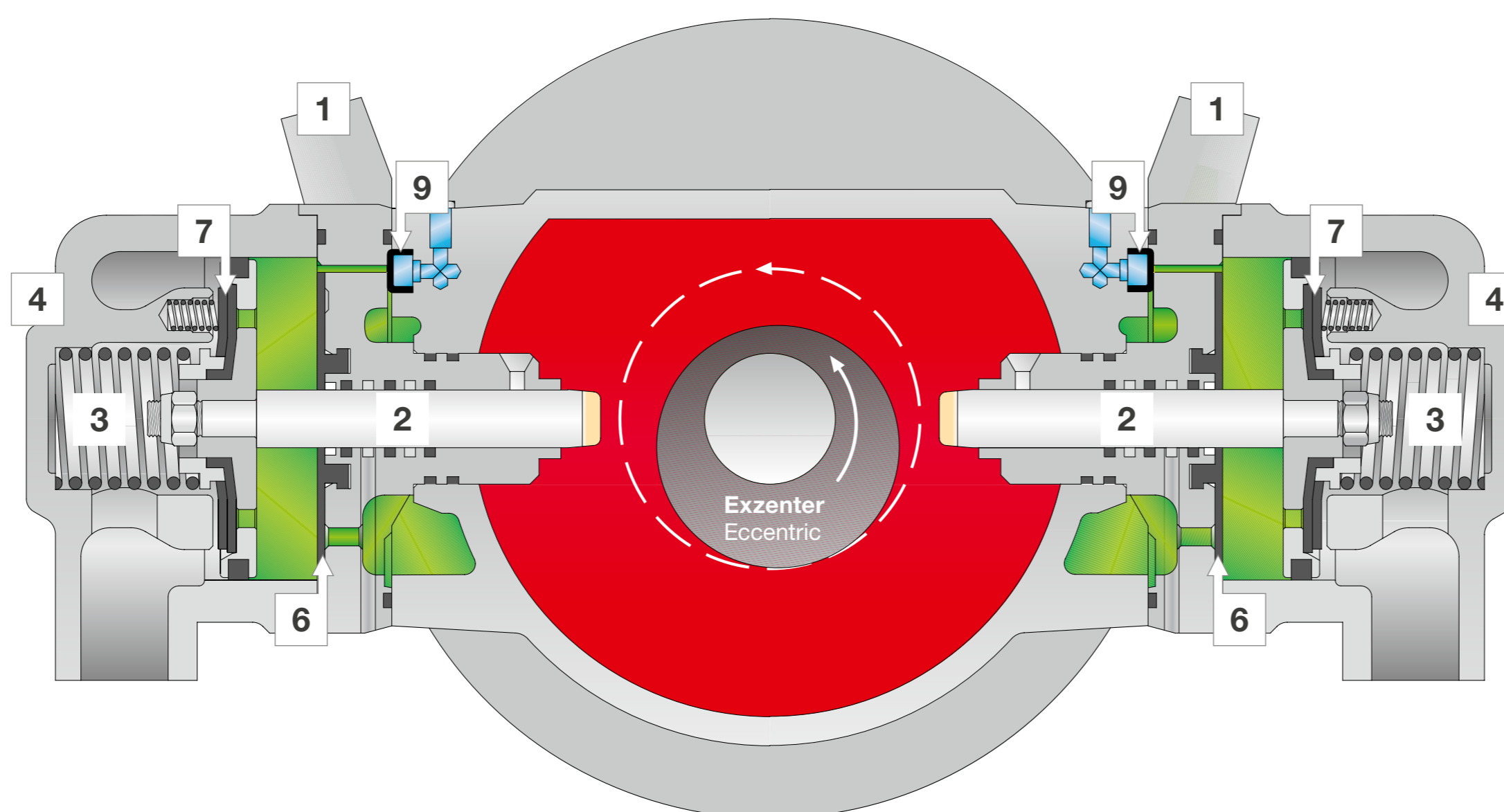
- 7 Auslassmembrane**
Outlet diaphragm
- 8 Leckwasserbohrung**
Bore for leaking water
- 9 Wiedereinschaltventil**
Reclosing valve

Technische Änderungen vorbehalten. Für Druckfehler übernehmen wir keine Haftung.
Subject to technical changes. We do not assume any liability for printing errors.

Albert Ziegler GmbH
Albert-Ziegler-Strasse 1
89537 Giengen/Brenz
Germany

Phone +49 (0)7322 951-0
Fax +49 (0)7322 951-211
info@ziegler.de

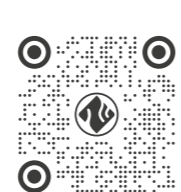

Schauposter digital zum Download
Explanation poster digital download



We provide
security.
www.ziegler.de

Ziegler

S3304-1-3-0123