

Z-Pump 10-10000-1H

Centrifugal fire pump Art. 022176

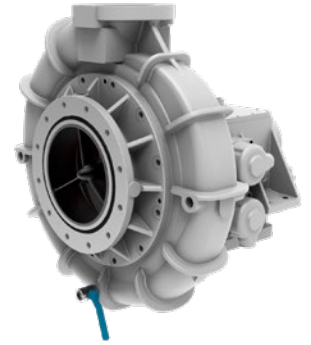

Norms/Standards	DIN EN 1028; CCCF
RPM max.	2,500 min ⁻¹
Power input max.	330 kW (450 HP)
Pump output max.	10,500 l/min at 10 bar and H _s 3.0 m
Torque max.	1,220 Nm
Weight	approx. 210 kg
Dimensions	L x W x H: 730 x 760 x 770 mm
Gear ratio	1:0.93 1:1.07 1:1.23 1:1.48
Priming system	Trokomat

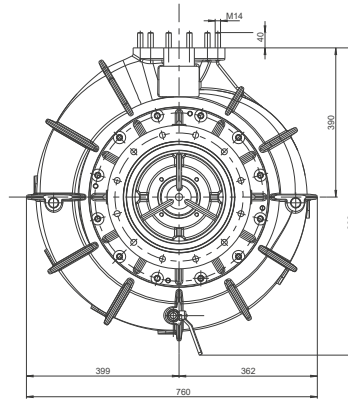
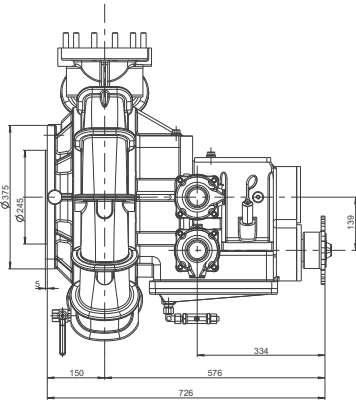
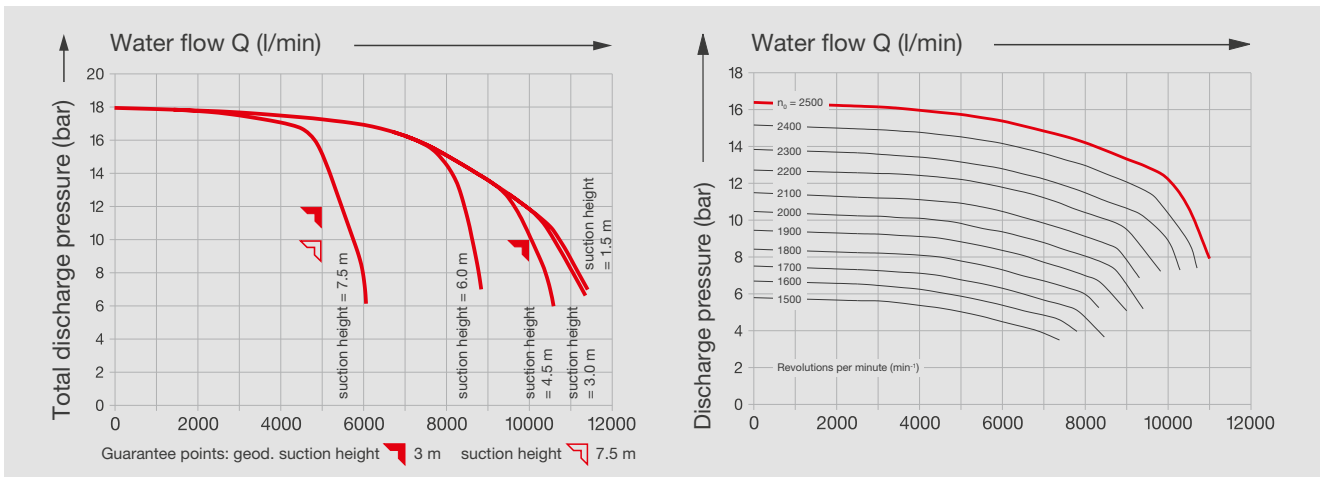

Illustrations may contain accessories and/or special equipment that are not part of the standard scope of delivery or service. Technical changes reserved. We cannot accept any liability for printing errors.



Albert Ziegler GmbH
 Albert-Ziegler-Strasse 1
 89537 Giengen/Brenz
 Germany

Phone +49 (0)7322 951-0
 Fax +49 (0)7322 951-211
 info@ziegler.de



We provide security.
 www.ziegler.de