

Z-Pump 10-4000-2H Centrifugal fire pump Art. 022128

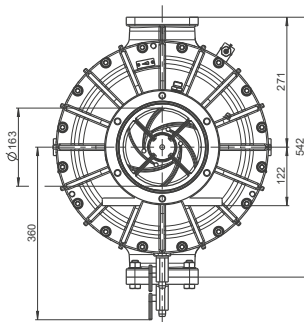

Norms/Standards	DIN EN 1028; CCCF
RPM max.	2,500 min ⁻¹
Power input max.	130 kW (177 HP)
Pump output max.	4,700 l/min at 10 bar and H _s 3.0 m
Torque max.	500 Nm
Weight	approx. 97 kg
Dimensions	L x W x H: 750 x 500 x 650 mm
Gear ratio	none
Priming system	Trokomat

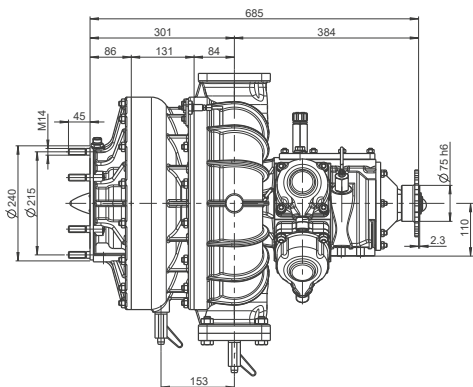
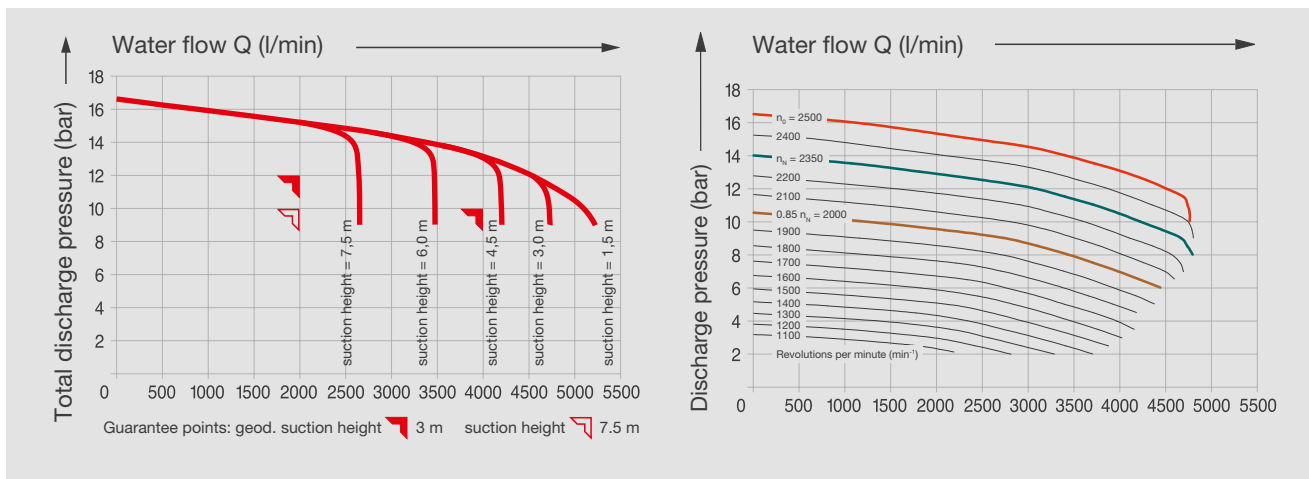

D3205-1-2-0426

Illustrations may contain accessories and/or special equipment that are not part of the standard scope of delivery or service. Technical changes reserved. We cannot accept any liability for printing errors.



Albert Ziegler GmbH
 Albert-Ziegler-Strasse 1
 89537 Giengen/Brenz
 Germany

Phone +49 (0)7322 951-0
 Fax +49 (0)7322 951-211
 info@ziegler.de



We provide security.
 www.ziegler.de