

Z-Pump 10-3000-1H

Centrifugal fire pump

Art. 022096

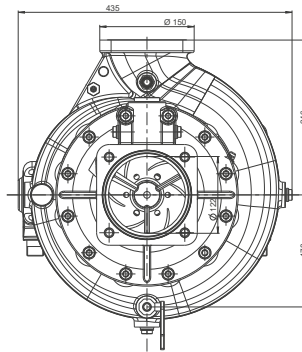
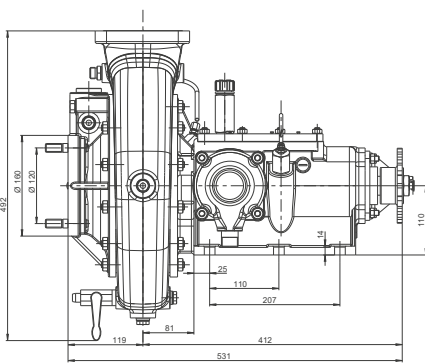

| | |
|-------------------------|---|
| Norms/Standards | DIN EN 1028; CCCF |
| RPM max. | 4,450 min ⁻¹ |
| Power input max. | 125 kW (170 HP) |
| Pump output max. | 3,800 l/min at 10 bar and H _s 3.0 m |
| Torque max. | 270 Nm |
| Weight | approx. 90 kg |
| Dimensions | L x W x H: 540 x 440 x 500 mm |
| Gear ratio | 1:1.23 1:1.35 1:1.48 1:1.81 1:2.10 1:2.50 |
| Priming system | Trokomat |

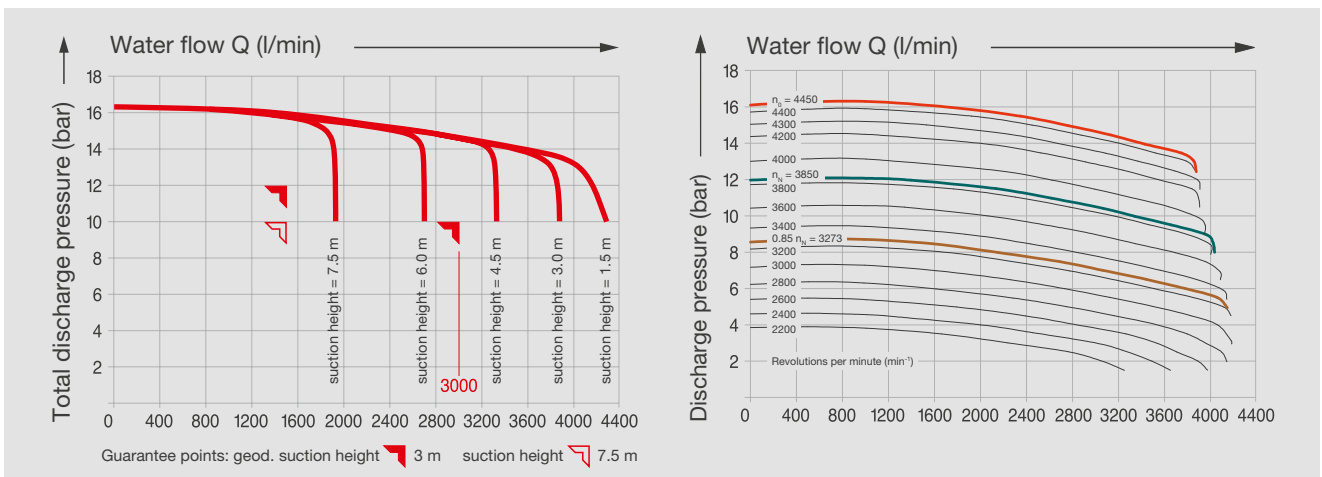

Illustrations may contain accessories and/or special equipment that are not part of the standard scope of delivery or service. Technical changes reserved. We cannot accept any liability for printing errors.

Albert Ziegler GmbH
 Albert-Ziegler-Strasse 1
 89537 Giengen/Brenz
 Germany

Phone +49 (0)7322 951-0
 Fax +49 (0)7322 951-211
 info@ziegler.de



We provide security.
www.ziegler.de